

4 GANG MASTER CONTROL SWITCH FOR NU-CRANKS

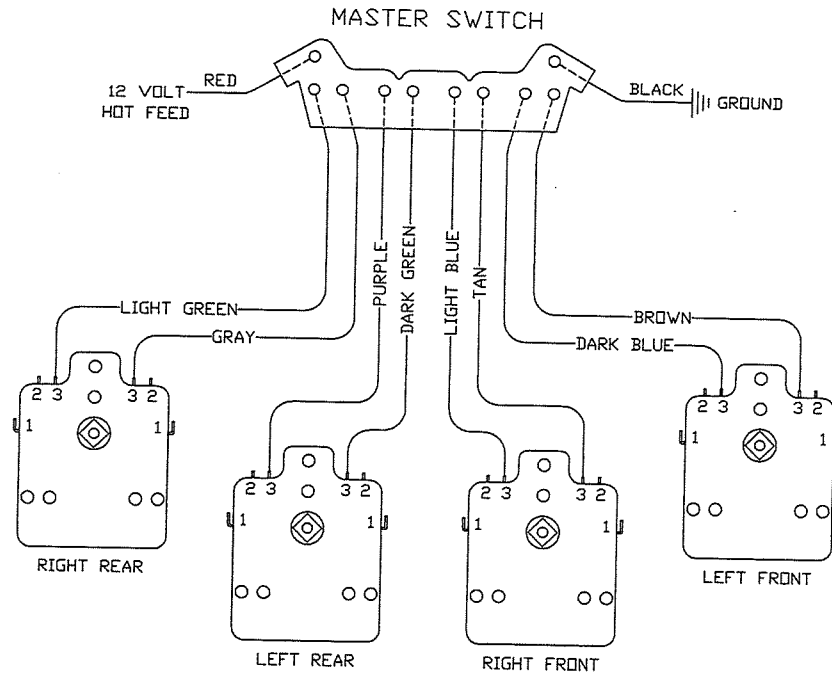

KEY TO NU-SWITCH TERMINALS

- #1 TO MOTOR (BLUE/BROWN)
- #2 HOT FEED (RED)
- #3 TO MASTER SWITCH BASED ON LEVER WIRES

Wiring Instructions for a 4 Gang Master Switch for Nu-Cranks

Note: Prior to installation, test the direction of the power window regulators for correct travel. It is easier to correct the travel direction prior to final installation. Review the notes for correcting the up/down travel below.

1. Determine which lever on the master switch will control which window. Wiring from left to right:
 - Lever 1 = light green; grey
 - Lever 2 = purple; dark green
 - Lever 3 = light blue; tan
 - Lever 4 = dark blue; brown
2. Remove the ground wire (black) from the original Nu-Crank Harness
3. Attach the appropriate 2 wires from the Master Switch to terminals #3 on the micro switches. New terminals included.
4. Attach Hot Feed (red) from the Master Switch AND all the Hot feeds (red) from Nu-Crank to a 12V Hot Source.
5. Attach the motor wires (blue/brown) from the Nu-Crank Switch to the motor.
6. Ground the Master Switch.

Correcting the up/down travel:

1. If a regulator is going the wrong direction from the Nu-Crank Switch - reverse the two wires at the motor plug. Special Instruction Sheet included in the original instruction packet.
2. If a regulator is going in the wrong direction from the Master Switch - reverse the two wires to terminals #3 on the Nu-Crank Switch.